

FT300

Mobile Cone Plant

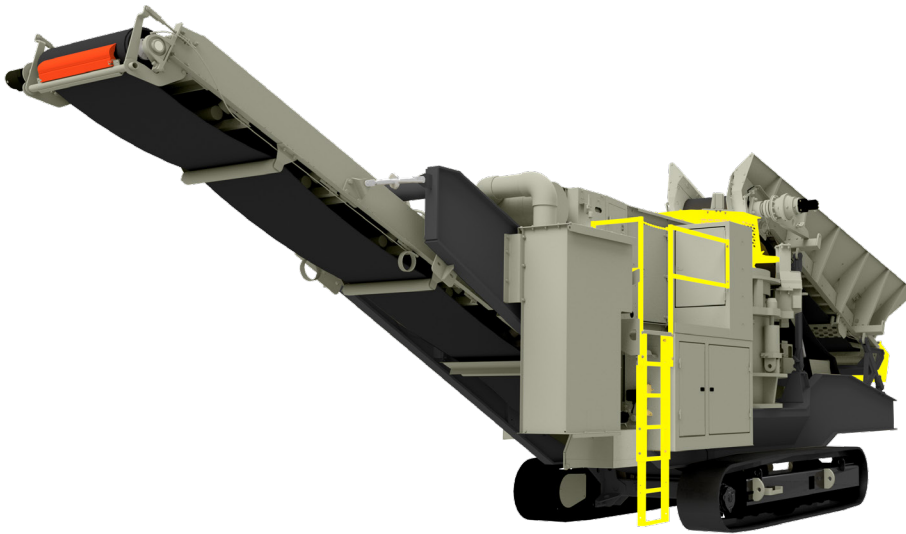

Kodiak® K300+Crusher

- High efficiency roller bearing design
- Remote Close Side Setting (CSS) adjustment
- Patented mechanical "crusher duty" cone brake
- Patented liner retention assembly
- Bronze field replaceable V-seat liners
- Permanently precision balanced
- Protected internal counter weights
- Baseframe tub liners field replaceable 400BHN
- Cold-climate oil recirculation
- Manganese liners (select from list of interchangeable liners)
- Crusher tools
- Operation and maintenance manuals
- Crusher feed hopper

Chassis

- I-beam/box frame design balanced for zero cribbing
- Components fold for transport
- Grease lines for easy maintenance

Heavy-duty Belt Feeder

- 48" feed conveyor
- Heavy-duty grade 1 belting
- Loading hopper with 6 cubic yard capacity

Under Crusher Conveyor

- 36" under crusher conveyor
- Grade II, 330 3 ply belting
- Fully skirted, 45-degree troughing rollers
- Tail section lowers for maintenance access

Power Unit

- Cummins QSX15 Tier 4 Final rated at 450hp/336kw
- 200gal/757L fuel tank
- Baghouse air filtration system

Controls

- Automatic feed regulation into the cone
- Engine overload protection
- Diagnostics with historical storage
- Color display with keypad
- 24V controls
- Wireless remote (track drive/feeder)
- Bowl float detection
- Dust suppression

Options

- Hydraulic cone brake
- Return conveyor
- Extended under-crusher conveyor with hydraulic fold
- CAT C13 Tier 3 rated at 440hp/328kW
- Cold weather kit (optional)

Physical/Operating Characteristics

Dimension	Standard	Metric
Operating length	47' 3½"	14.4m
Operating height	15' 11"	4.8m
Travel Height	11' 6½"	3.5m
Travel Width	9' 4¾"	2.9m
Feed Height	10' 8"	3.3m
Max Feed Size Up To	9 11/16"	246mm
Unit Weight (standard)*	95,000lb	43,090kg