

# GRADALL®

## FA50

### FIRE APPARATUS SPECIFICATIONS

FA50



#### System Specifications

- Thirteen cylinders**
- 1 tool: 4.75" ID, 3.0" rod (120 mm x 76 mm), 18.75" (476 mm) stroke.
  - 2 hoist: 4.75" ID, 3.0" rod (120 mm x 76 mm), 18.75" (476 mm) stroke.
  - 1 telescope: 3.5" ID, 2.559" rod (89 mm x 65 mm), 11' (3.35 m) stroke.
  - 1 jib: 4.75" ID, 3.0" rod (120 mm x 76 mm), 4'8" (1.42 m) stroke.
  - 4 outriggers extend and retract: 2.0" ID, 1.25" rod (51 mm x 32 mm), 4'6" (1.37 m) stroke.
  - 4 outriggers up and down: 3.5" ID, 2.559" rod (89 mm x 65 mm), 24" (610 mm) stroke.
- Two hydraulic motors**
- Swing, 20hp (15 kW); tilt, 20 hp (15 kW);

**Operating pressures:**

Hoist.....	4,000 psi	(276 BAR)
Tilt.....	2,600 psi	(179 BAR)
Swing.....	0,000 psi	(000 BAR)
Tool.....	4,000 psi	(276 BAR)
Telescope.....	4,000 psi	(276 BAR)
Jib .....	4,000 psi	(276 BAR)
Outriggers extend.....	2,600 psi	(179 BAR)
Outriggers retract.....	4,000 psi	(276 BAR)
Outriggers up.....	4,000 psi	(276 BAR)
Outriggers down.....	4,000 psi	(2769 BAR)

**Oil Capacity**  
Reservoir and hydraulic system capacity is 55 gallons (208 L). Pressurized reservoir with visual oil level gauges.

**Filtration System**  
10 micron return filter in tank  
  
Pressure-compensated, load-sensing valves with circuit reliefs in all circuits.

#### Hydraulic System

0 to 42 GPM (160 L/Min) up to 4000 psi

**PUMPS**  
Variable displace pressure compensating piston pump; Oil flow 0-42 GPM (0-160 L/min)

Overload indicator strobe light & audio system

Emergency pump and motor powered by chassis electrical system (12 volt or 24volt)

Manual control levers on the main hydraulic control valve assembly for upperstructure control and manual control levers on the outrigger valve assembly for outrigger controls.

Fin and tube-type oil cooler with thermal by-pass and relief valves.

#### Electrical System

A 12 volt electrical system is supplied by the main power supply of the chassis. A 24 volt system is optional on international chassis

#### Work Lights

Four high intensity work lights, two mounted on top of the main boom and two mounted on the bottom of the main boom.

#### Outriggers

Four independently operated or simultaneously operated outriggers. The outrigger legs extend and retract and move up and down for precise placement. Marker lights and flood lights are supplied for night operation.

#### Waterway

The 4' anodized aluminum waterway routes through the center pin, cradle and boom and connects to the adaptor for the Fifth Man piercing water cannon.

Fifth Man piercing water cannon capable of flowing water 1500 GPM and 120 psi . The Fifth Man cannon can also flow Class "A" and Class "B" foam.

#### Swing

Planetary transmission.  
  
Swing speed: 1.0 rpm.

Approximate working weight with attachment.  
  
Weight 23,000 lb (10,433 kg)

**Swing Brake**  
Automatic spring-set/hydraulic release wet disc parking brake. Dynamic braking is provided by the hydraulic system.

#### Optional Equipment

- Lifting Eye for Fifth Man
- Water Cannon for Fifth Man
- UL Stage One Certification (Not the entire truck)
- Hydraulic Pump (Depending on chassis spec)
- PTO (Depending on chassis spec)

#### Radio Remote Control Pack

All upperstructure functions and outrigger functions are controlled by a radio remote control pack. The operator can control the FA50 from up to 300' (92 m).

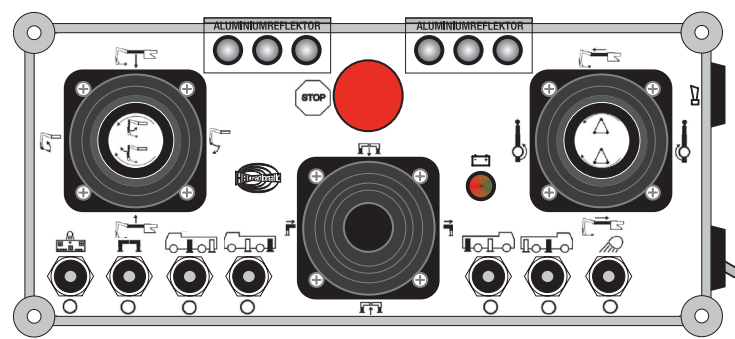

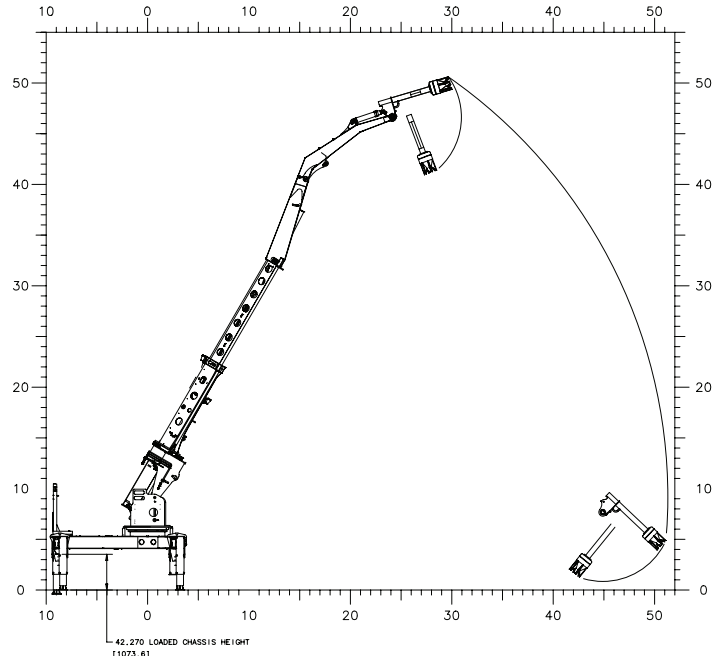
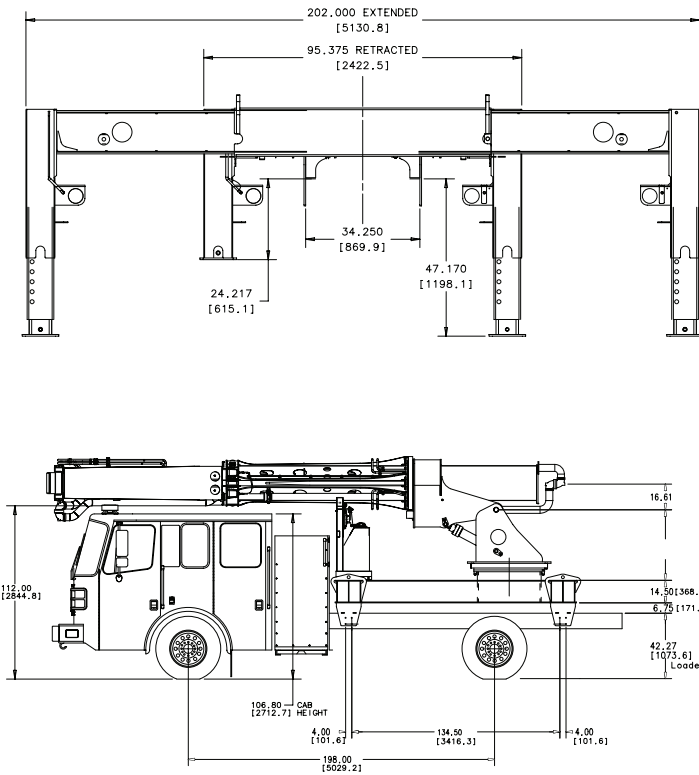

## Positioning Machine for a Lift

The machine must be on a firm, level surface with outriggers completely extended and lowered when making a lift.

The shorter the load radius, the greater the lift capacity. Position the unit to minimize boom extension and swing while keeping adequate distance from obstructions.

## Rated Lift Capacity Chart

BOOM CONFIGURATION	NOZZLE LIFT EYE	PIERCING ADAPTER LIFT EYE	TELESCOPE BOOM LIFT EYE
<b>BOOM AT ANY ANGLE/CONFIGURATION</b>	730 lbs (331 kg)	820 lbs (372 kg)	1490 lbs (676 kg)
<b>TELESCOPE BOOM FULLY RETRACTED</b>			
<b>BOOM AT ANY ANGLE</b>	1838 lbs (834 kg)	2225 lbs (1009 kg)	5400 lbs (2449 kg)
<b>STICK AND ADAPTER IN ANY CONFIGURATION</b>			
<b>TELESCOPE BOOM FULLY RETRACTED</b>			
<b>BOOM AT ANY ANGLE</b>	2750 lbs (1247 kg)	2750 lbs (1247 kg)	6100 lbs (2767 kg)
<b>STICK AT 90 DEGREES TO TELESCOPE BOOM</b>			
<b>ADAPTER FULLY CLOSED (cylinder fully extended)</b>			

**Note:** Values in lift chart above are with the outriggers in 'long-jack' configuration. The values are not valid for lifting with outriggers in 'short-jack' configuration.

# GRADALL®

Gradall Industries Inc.  
406 Mill Ave. SW, New Philadelphia, Ohio 44663  
Phone: 330-339-2211 Fax: 330-339-8468  
www.gradall.com



Certified ISO 9001

*It is Gradall Policy to continually improve its products. Therefore designs, materials and specifications are subject to change without notice and without incurring any liability on units already sold. Units shown may have optional equipment.*