

GRADALL®

XL 4240 V

ALUMINUM MILL
MAINTENANCE



SPECIFICATIONS

Engine

- Volvo TAD571 VE, Tier 4f, 4 cycle, inline 4 cylinder, liquid cooled, electronic controlled
- Vertical canister style lube and main fuel filters and fuel/water separation with manual feed pump attached to engine
- Water in fuel indicator and alarm

Gross Rating: 173hp @ 2200 rpm (129kW)
590 ft lb torque @ 1100-1500 rpm (800Nm)

Net Rating: 153 hp @ 2200 RPM (114kW)

- Variable viscous fan clutch system
- Vertical stacked hydraulic oil cooler, charge air cooler and radiator
- Block heater

Maximum slope: 30°

- 24 volt starter
- 100 amp alternator
- Two SAE #C31-S 1000 CCA batteries
- Two-stage dry type air cleaner with centrifugal pre-cleaner and safety element
- Vacuator valve
- Remote service indicator

Fuel tank capacity: 82 gal (310 L)

Operator Cab

- All-weather cab with tinted safety glass windows
- Acoustical lining
- Four-way adjustable operator's seat
- AM/FM radio
- Filtered fresh air heater, defroster and A/C
- Front window has heat-resistant glass
- Rear view mirror on left side
- Work lights
- Swing lights

Controls

- Two electronic joysticks
- Joysticks mounted on arm pods, independently adjustable for individual operator comfort and convenience
- Self-centering joysticks; when controls are released, power for movement disengages and swing brake set automatically

- Two electric foot pedals (with handles) control crawler travel speed and direction, crawler steering and crawler brakes
- Toggle switch on arm pod allows selection of two crawler speed ranges

Engine Controls and Instrumentation

- Key operated ignition/starter switch, throttle and main battery disconnect switch
- Air cleaner condition indicator
- Electronic monitor indicates fuel level, low battery charge, lube oil pressure, high coolant temperature, engine rpm and engine hours
- Fuel saving auto idle feature sends engine rpm to idle when control circuits are in neutral for seven seconds

Boom

- Three piece square telescoping boom
- Adjustable boom rollers with eccentric shafts
- Adjustable height and leveling
- No hydraulic circuits in boom

Hydraulic System

Pumps

- One load-sensing, axial piston pump; oil flow 0-110 gpm (0-416 L/min)
- Gear pump, 6 gpm (23 L/min)

System Monitor

- Electronic Monitor in Cab
 - Low hydraulic fluid level
 - High hydraulic fluid temperature
 - System working pressure
 - System pilot pressure

SYSTEM SPECIFICATIONS

- Two hoist: 5.0" ID, 3.0" rod (127 mm x 76 mm), 10.72" (272.3 mm) stroke
- Two leveling: 5.0" ID, 3.0" rod (127 mm x 76 mm), 25.9" (658.1 mm) stroke

Four Hydraulic Motors

- Swing, 64 hp (48 kW)
- Two propel motors, 120 hp (89 kW) each
- Hydraulic winch, 122 hp (91 kW)

Operating Pressures:

- Hoist..... 4,900 psi(331 BAR)
- Swing 4,200 psi(290 BAR)
- Telescope 4,900 psi(331 BAR)
- Propel..... 4,900 psi(331 BAR)
- Pilot System 550 psi (38 BAR)

Oil Capacity

- Reservoir system 65 gallons (246 L)
- Pressurized reservoir with visual oil level gauges

Filtration System

- 10 micron return filter
- 10 micron pilot filter
- Fin and tube-type oil cooler with thermal by-pass and relief valves
- Pressure-compensated, load-sensing valves with circuit reliefs in all circuits

Crawler Drive

- Dual range, high torque piston motor powers each track
- Three-stage planetary drive with integral speed limiting valve and automatic spring-set/hydraulic release wet-disc parking brake

Travel Speed: on flat, level surface:

High Speed: 3.4 mph (5.5 km/h)
Low Speed: 1.9 mph (3.1 km/h)

- Automatic two-speed control shifts crawler drive into low speed under difficult travel conditions
- Manual override switch for loading the machine for transport

Individual Track Control

- Tracks counter-rotate to pivot machine about the swing centerline
- Electronically operated travel alarm signals crawler movement in either direction

Swing

- Priority swing circuit with axial piston motor
- Planetary transmission

Swing Brake

- Automatic spring-set/hydraulic release wet-disc parking brake
- Dynamic braking provided by the hydraulic system

Function Forces

Rated Boom Force:

11,000 lbs (48.9 kN)

Weight

Approximate working weight with fuel tank half full and no operator.

Pad Size	Weight	Bearing Pressure
31.5" 800 mm	67,500 lb (30,617 kg)	8.0 psi (55.9 kPa)

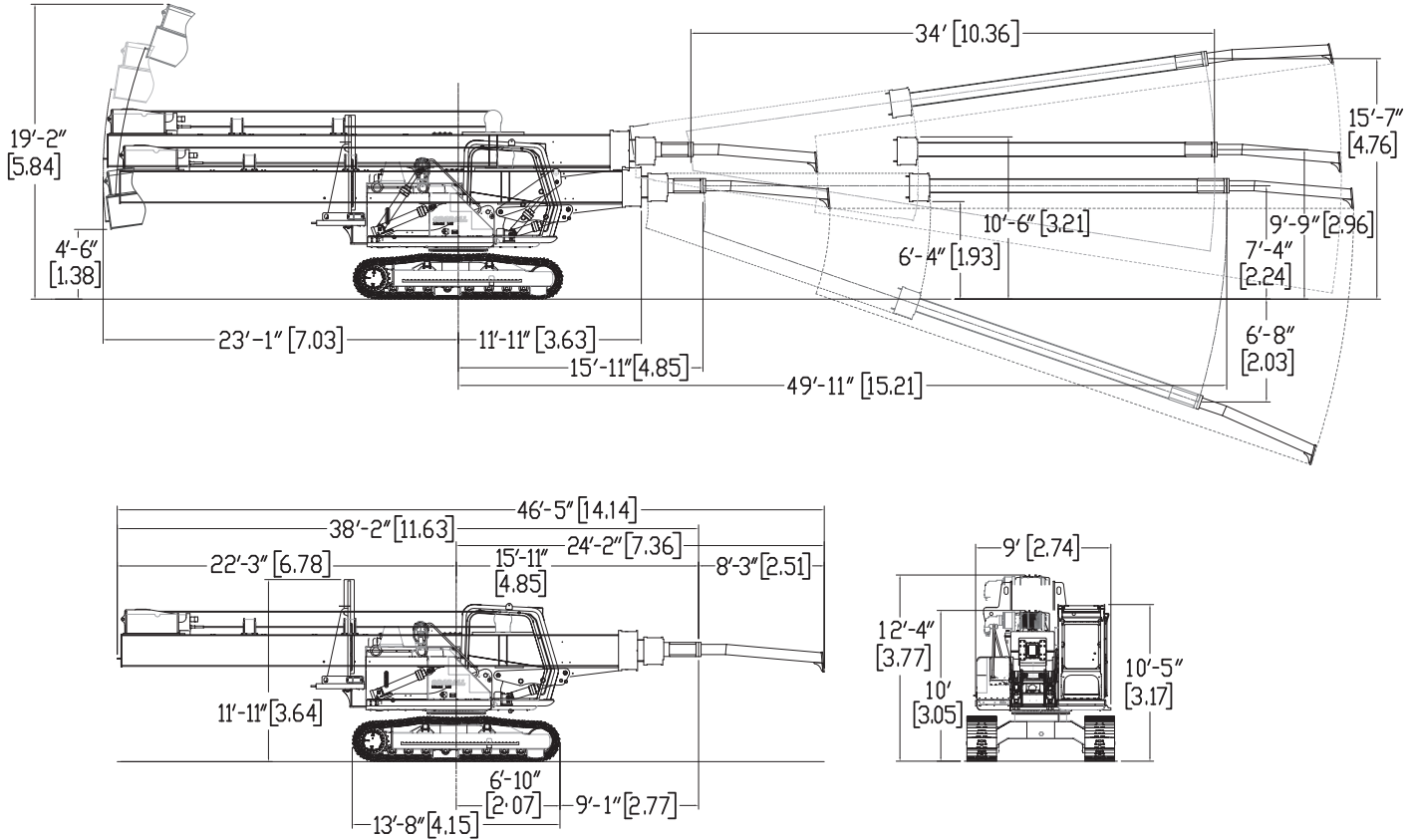

It is Gradall Policy to continually improve its products. Therefore designs, materials and specifications are subject to change without notice and without incurring any liability on units already sold. Units shown may have optional equipment.

GRADALL®

406 Mill Ave. SW, New Philadelphia, Ohio 44663
 Phone: 800-445-4752
 www.Gradall.com