

GRADALL® XL 4340 V

ALUMINUM MILL
MAINTENANCE



SPECIFICATIONS

Engine

- Volvo TAD571 VE, Tier 4f, 4 cycle, inline 4 cylinder, liquid cooled, electronic controlled
- Vertical canister style lube and main fuel filters and fuel/water separation with manual feed pump attached to engine
- Water in fuel indicator and alarm

Gross Rating: 173 hp @ 2200 rpm (129kW), 590 ft lb torque @ 1100-1500 rpm (800Nm)

Net Rating: 153 hp @ 2200 rpm (114kW)

- Variable viscous fan clutch system
- Vertical stacked hydraulic oil cooler, charge air cooler and radiator
- Block heater

Maximum slope: 30°

- 24 volt starter
- 100 amp alternator
- Two SAE #C31-S 1000 CCA batteries
- Two-stage air cleaner with high-efficiency pre-cleaner
- Vacuator valve
- Remote service indicator

Fuel tank capacity: 82 gal (310 L)

Operator Cab

- All-weather cab with tinted safety glass windows
- Acoustical lining
- Four-way adjustable operator's seat
- AM/FM radio
- Filtered fresh air heater, defroster and A/C
- Mirror on left side
- Operator's seat belt
- Work lights
- Swing lights

Controls

- Two electronic joysticks
- Joysticks mounted on arm pods, independently adjustable for individual operator comfort and convenience
- Self-centering joysticks and pedals; when controls are released, power for movement disengages and swing brake set automatically

- Tilting/telescoping steering column provides smooth, comfortable steering
- Hydraulic foot pedal controls braking functions, giving smooth performance with infinite control
- Travel speed is regulated with an electronic foot pedal control
- Switch on the FWD/REV selector provides 1st/2nd gear selection
- Independent rocker switches control stabilizers, axle oscillation and park brake

Engine Controls and Instrumentation

- Key ignition/starter switch; throttle and main battery disconnect switch
- Air cleaner condition indicator
- Electronic monitor indicates fuel level, low battery charge, lube oil pressure, high coolant temperature, engine rpm and engine hours
- Fuel saving auto idle feature sends engine rpm to idle when control circuits are in neutral for seven seconds

Boom

- Three piece square telescoping boom
- Adjustable boom rollers with eccentric shafts
- Adjustable height and leveling
- No hydraulic circuits in boom

Hydraulic System

Pumps

- One load-sensing, axial piston pump; oil flow 0-110 gpm (0-416 L/min)
- Tandem gear pump (steering, brake/pilot) 10 gpm (38 L/min), 6 gpm (23 L/min)

System Monitor

- Electronic Monitor in Cab
 - Low hydraulic fluid level
 - High hydraulic fluid temperature
 - System working pressure
 - System pilot pressure

SYSTEM SPECIFICATIONS

- Two hoist: 5.0" ID, 3.0" rod (127 mm x 76 mm), 10.72" (272.3 mm) stroke
- Two leveling: 5.0" ID, 3.0" rod (127 mm x 76 mm), 25.9" (658.1 mm) stroke
- Two single-acting axle oscillation cylinders: 4.528" ID, 4.528" rod (115 mm x 115 mm), 6.25" (159 mm) stroke

Three Hydraulic Motors

- Swing, 64 hp (48 kW)
- Hydraulic winch, 122 hp (91 kW)
- Propel, 113 hp (84 kW)

Operating Pressures:

- Hoist..... 4,900 psi(331 BAR)
- Swing 4,200 psi(290 BAR)
- Telescope 4,900 psi(331 BAR)
- Propel..... 4,900 psi(331 BAR)
- Pilot System 550 psi (38 BAR)
- Braking & Steering.. 2,400 psi(165 BAR)
- Blade & Stabilizers.. 4,000 psi(207 BAR)

Oil Capacity

- Reservoir system 65 gallons (246 L)
- Pressurized reservoir with visual oil level gauges

Filtration System

- 10 micron return filter
- 10 micron pilot filter
- Fin and tube-type oil cooler with thermal by-pass and relief valves
- Pressure-compensated, load-sensing valves with circuit reliefs in all circuits

Undercarriage

- Full-time 4-wheel drive transfer case delivers power from the hydraulic drive motor to the drive axles
- Both axles equipped with internal wet-disc type service brakes
- Steering axle fitted with oscillation lock cylinders
- Optional stabilizer and blade

Tires: 10.00 x 20 Super-Lug (optional foam filled or solid)

Axles: ZF Model 3070 (FTF 2090)

Transmission: ZF Model HL 290

Drive Motor: Rexroth A6 Series, 160cc/Rev

Undercarriage Drive

- Variable displacement high torque piston motor powers two-speed power shift transmission
- Speed mode selection can also be done while moving
- Electronically operated travel alarm signals excavator movement

Travel speed on flat, level surface—mph km/hr):

	Creep Mode	Standard Mode
First Gear	1.4 mph (2.2 kmh)	4.6 mph (7.4 kmh)
Second Gear	5.5 mph (8.9 kmh)	17.5 mph (28.2 kmh)

Swing

- Priority swing circuit with axial piston motor
- Planetary transmission

Swing Brake

- Automatic spring-set/hydraulic release wet-disc parking brake
- Dynamic braking provided by the hydraulic system

Weight

- 68,220 lbs (30,944 kg)
- Outriggers:** 2,720 lbs (1,234 kg)
Blade: 1,529 lbs (694 kg)

Function Forces

Rated Boom Force:

11,000 lbs (48.9 kN)

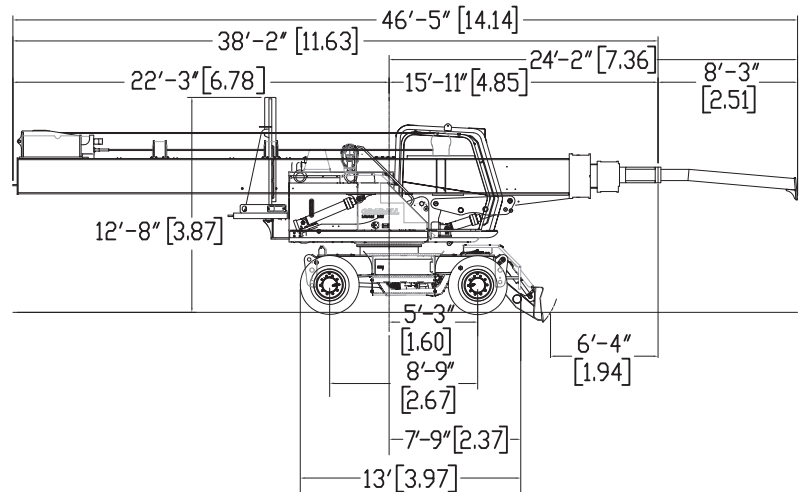
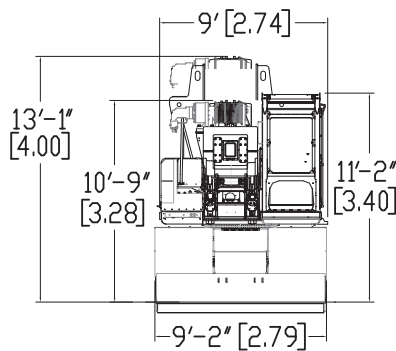
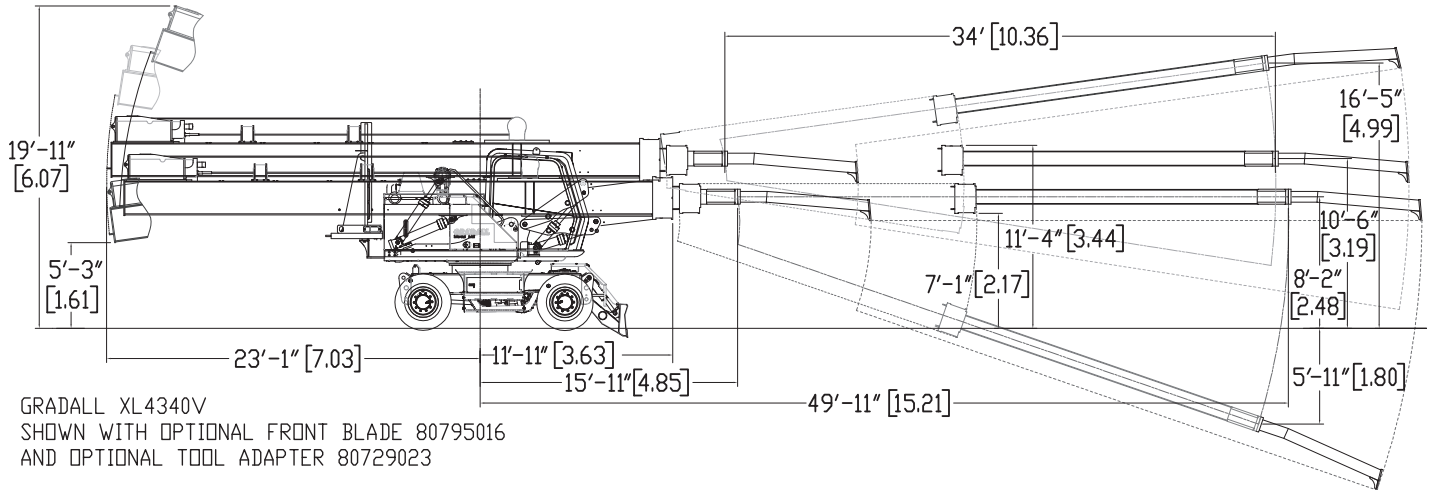

It is Gradall Policy to continually improve its products. Therefore designs, materials and specifications are subject to change without notice and without incurring any liability on units already sold. Units shown may have optional equipment.

GRADALL®

406 Mill Ave. SW, New Philadelphia, Ohio 44663
 Phone: 800-445-4752
 www.Gradall.com